

# Real adventures only start where sealed roads stop.

With the Mercedes-Benz Unimog as a camper or long distance touring vehicle.



Mercedes-Benz  
Trucks you can trust

# For the explorers among the wayfarers.

The Mercedes-Benz Unimog.

**Let your imagination run free.** Regardless of whether you're following in the footsteps of great explorers or discovering places that no-one else has found before you, the camper and long-distance touring vehicles based on the Mercedes-Benz Unimog make it possible. The vehicles of the new Unimog generation can be converted into reliable companions on your travels – either as an outstandingly mobile off-road camper or as a sturdy and reliable expedition vehicle for going on extreme adventures. Wherever your path leads, you can be sure of incredible reliability, great robustness, unique off-road capabilities and high payloads. The Unimog is noted for its superb handling and easy-to-use controls as well as a chassis that will meet all of your expectations. What's more, we can also supply a wide range of technical modifications ex factory in accordance with your needs. Our close cooperation with specialised body builders allows us to realise unlimited individual requests. In short: everything is just as you would expect it to be from Mercedes-Benz – and not just during your maiden voyage but for the many thousands of kilometres thereafter.





**ALWAYS THERE FOR YOU,  
WHEREVER 'THERE' MAY BE.**

Wherever you put your Unimog to work, Mercedes-Benz is close at hand. At over 650 Unimog Service Support Points in more than 130 countries around the world, we will take care of your Unimog straight away if you need us to. With the same care and attention to detail, the same expertise and the same technical resources that we put into its original assembly. This comes courtesy of our international service network manned by knowledgeable Unimog partners.

# At home in places which others can't even get to.

The Unimog sets the standard for off-road mobility.

**Highly agile off-road, extremely robust, very reliable and tried-and-tested thousands of times.** The Unimog allows you to cope with any challenge or terrain that you encounter. Worldwide. You will set out on each trip with total confidence: fording, climbing and mastering rough terrain are part and parcel of the genes of the Unimog. And, when required, it's also great on-the-road. Powerful, reliable engines supply an output of up to 170 kW (231 hp). Coupled to an almost indestructible and extremely agile off-road drive system and chassis concept, it can tackle mud, scree and sand as well as snow, ice and deep riverbeds – even with customised attachments and body solutions. And of course you don't need to do without the comfort and ergonomic controls typical of Mercedes-Benz vehicles even if you do decide to follow routes and destinations which others are unable to or which they simply fear.



There is hardly another vehicle that comes close to the capabilities of the Unimog – it sports an impressive fording ability of up to 1.2 m, the tirecontrol plus central tyre inflation system, large approach and departure angles as well as high ground clearance of around 0.5 m thanks to the use of portal axles and torque tube technology.



State-of-the-art cab with a feel-good atmosphere: details such as its multifunction steering wheel, hands-free mobile phone, adjustable steering column and easy-to-operate controls provide comfort similar to that of car. Auxiliary heating and engine pre-heating are also available as optional extras.



As well as the standard cab with seating for up to three people, a double cab with room for a driver and six passengers is also available. It provides enough space for an additional rear bench or two additional single seats.



**EXTREMELY AGILE OFF-ROAD CAPABILITIES:**

- + All-wheel drive with three 100% differential locks
- + Up to 30° diagonal axle articulation due to coil springs with an extremely long pitch
- + High ground clearance of 0.5 m due to portal axles
- + Up to 100% climbing ability due to its off-road gear ratio
- + Fording capability up to 1.2 m
- + Well-established and efficient central tyre inflation system with newly designed controls ex factory
- + Short frame overhangs for large angles of approach and departure at front and rear
- + Very favourable ramp angle due to high position of the transmission
- + Very resilient, offset frame and low vehicle centre of gravity
- + Extremely well protected drivetrain due to torque tube technology
- + Operational reliability between -40 and +50 °C
- + Automatic 8-speed manual transmission with off-road gear ratio

# Stronger than ever.

The Unimog with added performance: U 5030 6-cylinder engine with an output of 220 kW (299 hp).

**Even greater performance – for all those who don't want to be held up by anything.** In cooperation with its conversion partner Hellgeth Engineering Special Vehicle Construction, Mercedes-Benz is able to supply a special Unimog model with greater engine output: the U 5030. Instead of four cylinders, the Unimog is powered by six cylinders with a capacity of 7.7 l, an output of 220 kW (299 hp) and a strong maximum torque of 1200 Nm. This performance is possible by using the OM 936 LA engine. It is a common-rail engine and belongs to the new generation of state-of-the-art Mercedes-Benz engines which comply with the Euro VI emissions standard. Despite this, the U 5030 is just as robust with great off-road capabilities. To increase traction, it features permanent all-wheel drive. The altered drivetrain provides increased driving dynamics when off road and superior handling when travelling.



In coordination with conversion partner Hellgeth Engineering Special Vehicle Construction it is also possible to realise a wide range of other highlights such as multi-piece alloy wheels and superior interior leather furnishings in an exclusive sporting design. As an option, we can also supply a customised chassis configuration to suit the customer's requirements, for example, for an expedition or rally vehicle.

# A strong team.

The new extremely agile off-road Unimog U 4023/U 5023 and the special model U 5030.

Model	U 4023	U 5023	U 5030
Engine (Euro VI)	OM 934 LA	OM 934 LA	OM 936 LA
Capacity	5132 cm <sup>3</sup>	5132 cm <sup>3</sup>	7700 cm <sup>3</sup>
Power output	170 kW/231 hp	170 kW/231 hp	220 kW/299 hp
Max. torque	900 Nm at 1200–1600 rpm	900 Nm at 1200–1600 rpm	1200 Nm at 1200–1600 rpm
Battery capacity (standard/special equipment)	100/170 Ah	100/170 Ah	100/170 Ah
Tank capacity (standard/special equipment)	Rated volume 160/235 l	Rated volume 160/235 l	Rated volume 160/235 l
Recommended tyre constellation (tyres/rims)	365/80 R 20	395/85 R 20	395/85 R 20
Drive type	Engageable all-wheel drive	Engageable all-wheel drive	Permanent all-wheel drive
Wheelbase	3850 mm	3850 mm	3850 mm
Perm. GVW (max. with relevant special equipment)	7.5/10.3 t	13 t	13 t
Angle of approach (front)/departure (rear)	42°/46°	46°/50°	46°/50°
Body-mounting space (max. L × W × H)	4100 × 2280 × 1400 mm	4100 × 2280 × 1400 mm	4100 × 2280 × 1400 mm
Fording depth (standard/special equipment)	0.8 m/1.2 m	0.8 m/1.2 m	0.8 m/1.2 m

U 4023 BlueTEC 6

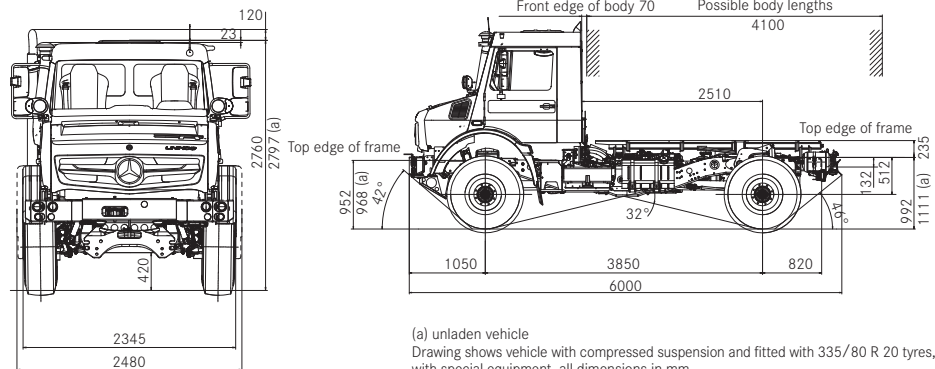

U 5023 BlueTEC 6

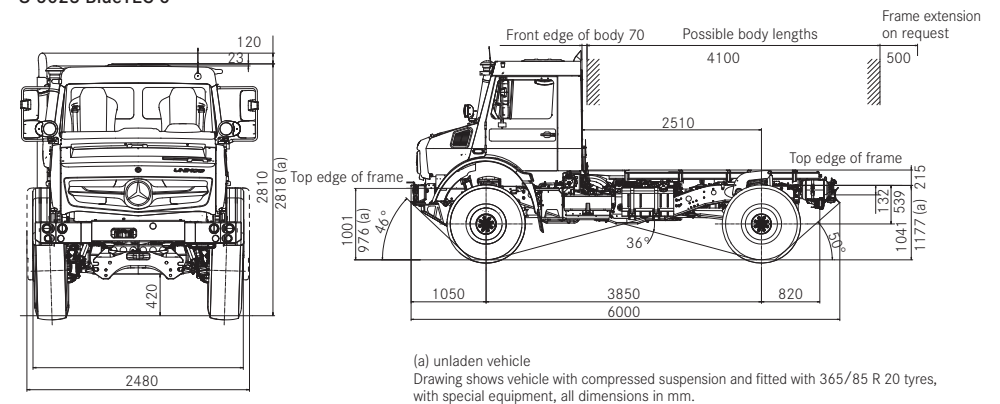

**Please note:** changes may have been made to the product since this publication went to press (2015/05/27). The manufacturer reserves the right to make changes to the design, form, colour and scope of delivery during the delivery period, provided that these changes, whilst taking into account the interests of the vendor, can be deemed reasonable with respect to the purchaser. Where the seller or the manufacturer uses symbols or numbers to describe an order or the subject of an order, no rights may be derived solely from these. The illustrations may show accessories and items of optional equipment which are not part of the standard specification. Colours may differ slightly from those shown in this publication, owing to the limitations of the printing process. This publication may contain models and services which are not available in certain countries. Statements on legal and fiscal regulations and effects apply only to the Federal Republic of Germany at the time this publication went to press. To find out about the current status of these regulations and their implications, please ask your Unimog Dealer. [www.mercedes-benz.com/specialtrucks](http://www.mercedes-benz.com/specialtrucks)